

MIX 4D pump group - designed for heating systems in modern and traditional boiler rooms. The pump group is a factory-new set of devices equipped with a modern Grundfos pump. It is fitted with ESBE actuator and 4-way mixing valve ensuring optimum performance of the circuit. Thermometers in ball valves allow controlling the temperature, and additionally a non-return valve is built in at the low parameter to prevent backflow. The whole group is enclosed in thermal insulation made of EPP. The device is intended for wall installation.

Parameter	Value
Dimensions	470 x 245 x 160 mm
Connections	
- installation side	1" Female
- boiler side	1" Male
Spacing	125 mm
Max. operational temperature	110 °C
Thermometer scale	0-120 °C
Check valve	Yes - (in the ball valve at low parameter)
Max. pressure	6 bar
Pump type	Grundfos UPM3 Auto 25-70
EEL	<=0,20
Pump installation length	180 mm
Mixing valve	ESBE VRG 142
KVS valve	6.3
Actuator	ARA 561
Body material	Valves - Brass, /Piping - Copper + Brass
Insulation material	EPP
Sealing components	EPDM, Klingierite
Medium	Water or Water-Glycol

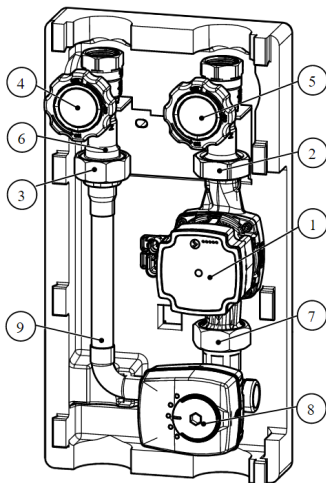

1. GRUNDFOS UPM3 AUTO 25-70 180 PUMP
2. HIGH PARAMETER BALL VALVE
3. LOW PARAMETER BALL VALVE
4. LOW PARAMETER 0-120°C CONTACT THERMOMETER
5. HIGH PARAMETER 0-120°C CONTACT THERMOMETER
6. LOW PARAMETER CHECK VALVE WITH MANUAL LOCK
7. ESBE VRG 142 4-WAY MIXING VALVE
8. ESBE ARA 561 ACTUATOR
9. LOW PARAMETER PIPE PART