

# Installation instruction

of the flat solar collectors models  
**ES1V2.0, ES1V2.65, ES2V/2.0 AL,**  
**ES2V/2.65, ES2H/2.65**  
on the inclined tile roof.

04/2012

Get acquainted before starting the installation.



## 1. Introduction

### Lightning protection



In case the height at which the collectors are to be installed exceeds 20 metres and a building is not equipped with the lightning protection it is necessary to connect all electrically conducting elements with an earth rod (minimal earth rod cross-section – 16mm<sup>2</sup>), and then with a compensating potential.

In case the height at which the collectors are to be installed does not exceed 20 metres it is not necessary to provide the lightning protection.

If the building is equipped with the lightning protection it is important to check the connection of the solar system to the lightning protection. That task should be performed by an electrician.

### Recycling



Completely used up solar collectors can be returned to the manufacturer. The returned solar collectors shall be utilized by the manufacturer in the way which is the least burdensome for the natural environment.

## 2. Safety during installation

**Before commencing the installation work it is necessary to immediately get acquainted with the safety tips!**

### 2.1. Notes included in the instruction.

The installation instruction includes important information concerning safety and proper positioning of the collectors on the roof as well as the correct execution of the hydraulic connection. Drawings and information included in the instruction apply to a vertical installation of the collectors.

Installation of the collators can only be performed by qualified personnel with professional experience in the field of water supply and gas systems.

Upon completion of works an installer should hand over the installation instruction to a customer and clearly explain the principles of operation and directions essential to a proper operation of the solar system.

### 2.2 Application

This instruction includes a description of an assembly set to carry out the installation of solar collectors (vertically and horizontally) on the roof with the inclination ranging from 30° up to 65°.

The assembly set shall exclusively be used to perform the installation of solar collectors, it must not be used to install different devices on the roof. Installation of only solar collectors on the supporting structure guarantees its safety of operation.

## 3. Before commencing the installation.

### Directions!



As the work on the roof can be dangerous it is recommended to hire a roofwork firm.

### DANGER OF GETTING SCALDED.



In case the collectors and assembly materials are exposed to solar radiation for a long time, there is a risk of getting scalded by hot elements.

In order to avoid the danger of scalding you should:

- use protective clothing,
- cover the collectors and the assembly materials with canvas cover (thanks to which the heating up by sunbeams will be reduced).

### 3.1 Completeness of delivery



Before commencing the installation it is necessary to check if the delivery is complete and the delivered components are free of damage.

- in case of discovering any damages the defected elements or parts should be immediately replaced,
- the replacement needs to be carried out with the application of original spare parts only.

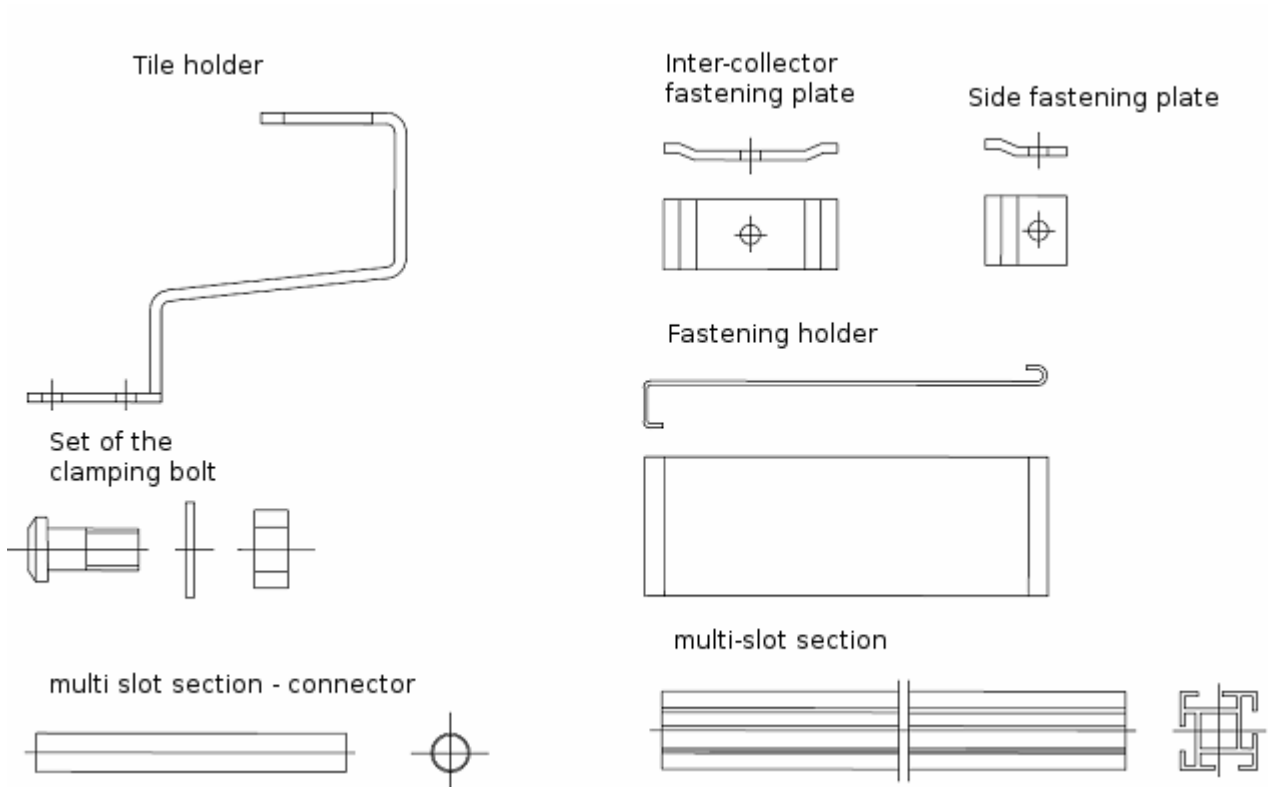



### 3.2 Transport and storage.

- during transport the collector connectors are protected by rubber caps,
- collectors should be stored in a dry place. In case the collectors are stored outside they should be protected against weather conditions.

### 3.3 Technical Documentation

Solar installation set consists of different components. Before installing any of the components you should become familiar with an adequate instruction.



A separate installation instruction is attached to a given device or a piece equipment.

- Installation instruction of solar collectors,
- installation instruction of the pump group,
- installation instruction of the solar controller,
- installation instruction of the hot water container.

### 3.4 Additional tools and equipment

- level,
- harness with protective rope (to work high above ground),
- scaffolding, a roof ladder or a crane.

### 3.5 Location of a collector

Potential quantity of the absorbed radiation depends on a proper location of the absorber in relation to falling sunbeams.

Optimum is a perpendicular position of a collector surface in relation to the falling solar radiation.

Recommended location of a collector:

- inclination angle:
  - 40 – 45° for a year-long installation,
  - approximately 30° for installations used in summer,
  - approximately 60° for installations used in winter,
- positioning of a collector in the southern direction (or approximate to the southern direction).

**Solar collectors must not be installed at the inclination below 30° or over 75°.**

It is recommended to install the collectors on the southern roof slope. During the installation work particular attention should be paid to protect the collectors from being overturned by strong winds. **Permissible snow and wind load amounts to max. 2,0 kN/m<sup>2</sup>.**

Collectors field should be located in such a way that the absorber will not be shadowed by the adjacent buildings, trees, etc.

In case of a larger number of collector fields it is important that the front row of the collectors do not shadow the back one.

### 3.6 Technical data for the flat collector models: ES1V/2.0, ES1V/2.65, ES2V/2.0 AL, ES2V/2.65, ES2H/2.65

Flat collector	Symbol	ES1V/2.0	ES2V/2.0 AL	ES1V/2.65	ES2V/2.65	ES2H/2.65	Unit
Width	A	1006	1006	1120	1120	2356	mm
Height	B	2007	2007	2356	2356	1120	mm
Depth	C	85	85	85	85	85	mm
Collector weight	m	40	40	49	49	49	kg
Area	S	2,02	2,02	2,65	2,65	2,65	m <sup>2</sup>
Connectors: Cu pipe	Φ	22	22	22	22	22	mm
Fluid volume	V	1.8	1.8	2.2	2.2	2.2	dm <sup>3</sup>
Max working pressure	p <sub>max</sub>	6.0	6.0	6.0	6.0	6.0	bar
Optimum flow min. - max.	m	60-90	40-60	75-105	75-105	75-105	dm <sup>3</sup> /h

### 3.7 Required space

#### ES1V/2,0 and ES2V/2,0 AL for vertical installation

Required about 2200 mm in height and 1200 mm in width for the first collector and + 1110 mm in width for each consecutive one. In case of mounting a collector on the inclined roof the minimum distance between collectors and the roof edge is 1m.

#### ES1V/2,65, ES2V/2,65 for vertical installation

Required about 2560 mm in height and 1320 mm in width for the first collector and + 1220 mm in width for each consecutive one. In case of mounting a collector on the inclined roof the minimum distance between collectors and the roof edge is 1m.

#### ES2H/2,65 for horizontal installation

Required about 1320 mm in height and 2560 mm in width for the first collector and + 5210 mm in width for each consecutive one. In case of mounting a collector on the inclined roof the minimum distance between collectors and the roof edge is 1m.

## 3.7 Flow resistance for collectors

**ES1V/2,0**

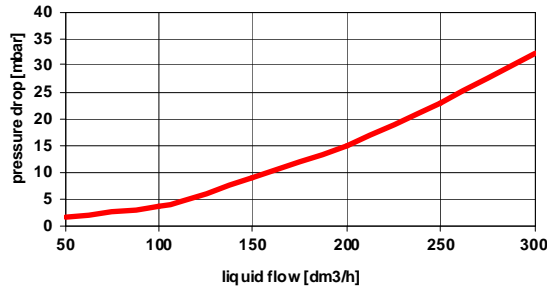

**ES1V/2,65**

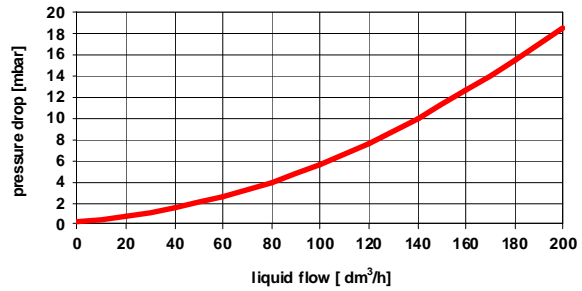

**1-10 x ES2V/2,0 AL**

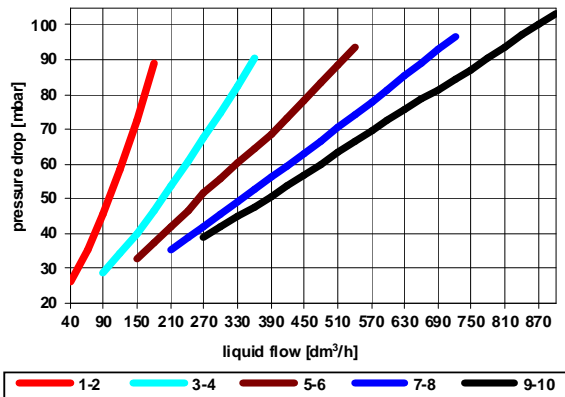

**1-10 x ES2V/2,65 i ES2H/2,65**

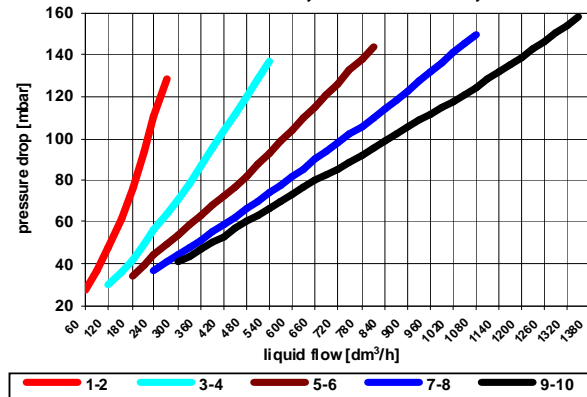

## 3.8 Warranty conditions of the installation and use of the collectors ES2V/2.0 AL with aluminum absorber

It is allowed to use only solar fluids that is accepted and offered by the producer, e.g. ENSOLICOL-AL -30,

It is allowed to wash the solar thermal system and perform the leak test only with solar fluid,

The solar thermal system must be closed (hermetic):

- the solar system can not contain automatic vents (potential place through the installation can get into air),
- before the first start, the solar system must be completely deaerated, and be leakproofed by the plumber,
- any leaks are associated with getting air into the solar thermal system with maximize the risk of corrosion. Once air get into the solar system the solar fluid must be replaced.

It is allowed to use only connections systems that are offered by the producer,

It is recommended to do the solar system with flexible stainless steel tubes or steel tubes. It is forbidden to connect directly the connector pipe of the collector witch any copper or brass parts of the solar system witch increases the possibility of electrochemical corrosion.

## 4. Spacing of tile holders.

### Directions!

The provided values of spacing for tile holders are only rough values and they should be observed approximately.

In case of corrugated tiles the factor which is essentially decisive for the tile holders is the location of hollows on the roof surface.



### Number and spacing of tile holders

Two pairs of tile holders are needed for the first collector (top and bottom). One pair of holders more should be used for each next collector, as per the table below.

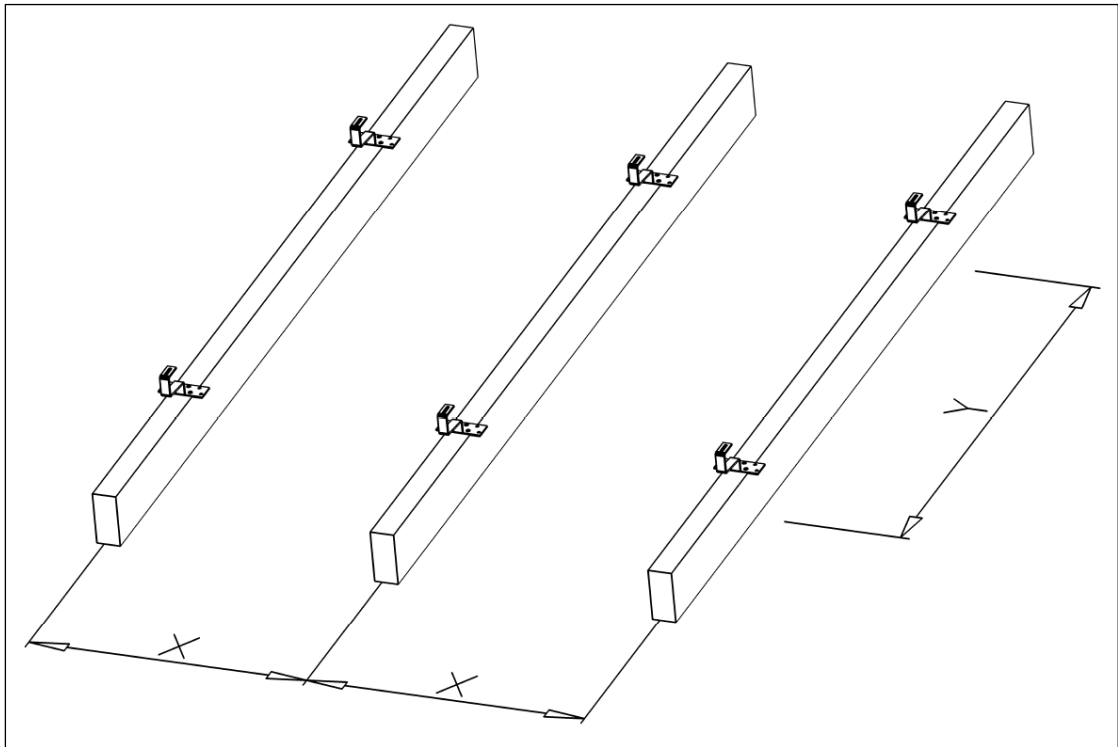

#### 4.1 Horizontal distance between the tile holders - X.

Number of collectors	Number of tile holders	distance of triangles [mm]		
		ES1V/2,0 ES2V/2,0 AL	ES1V/2,65 ES2V/2,65	ES2H/2,65
1	2	0,805	0,920	2,155
2	3	0,955	1,070	2,335
3	4	1,005	1,120	2,390
4	5	1,030	1,145	2,420
5	6	1,045	1,160	2,440

#### 4.2 Vertical distance between the tile holders - Y

The distance between the upper and bottom section should be in the range :

ES1V/2,0; ES2V/2,0 AL: Y = 1226 – 1626 mm

ES1V/2,65 ; ES2V/2.65: Y = 1583 – 1683 mm

ES2H/2.65: Y = 770 – 870 mm

## 5. Installation on the inclined roof

### 5.1 Installation of ridge beams

The first step is to fix the tile holders, following the guidelines contained in section 4 Bolt pitch tile

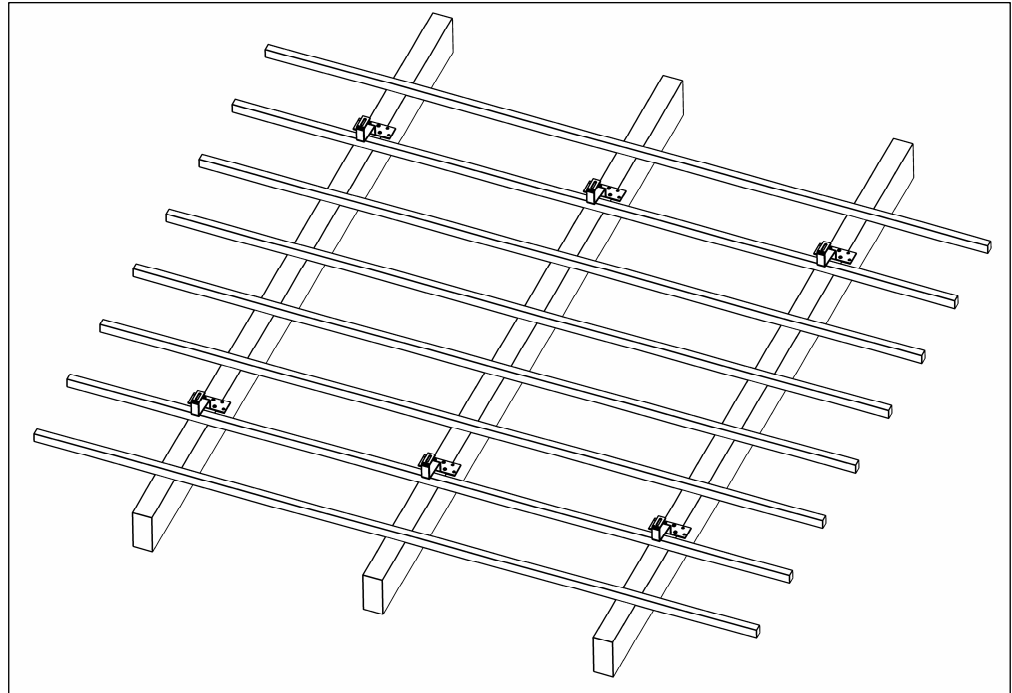

- insert a row of tiles under the already existing ones
- on the planned height screw the provided tile holders to the wooden laths (4 screws 6x40)

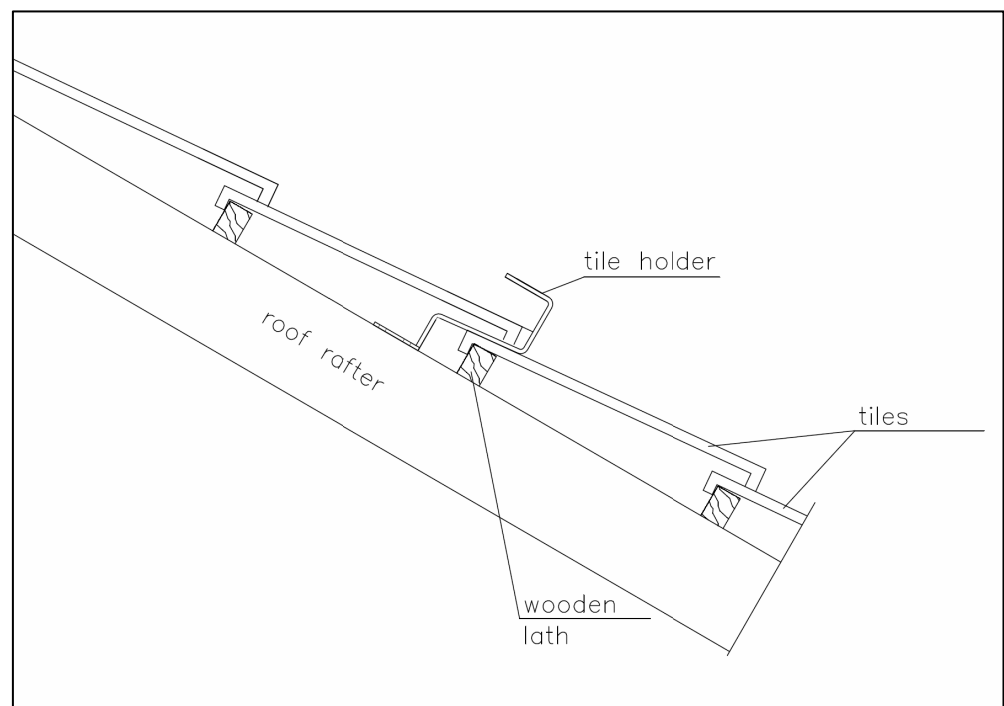

Tile holders should be fixed on the tile so that part of the supporting structure was in its cavity (for corrugated roofing). You can adjust by screwing the tile holders to the wooden lath in the configurations shown below:

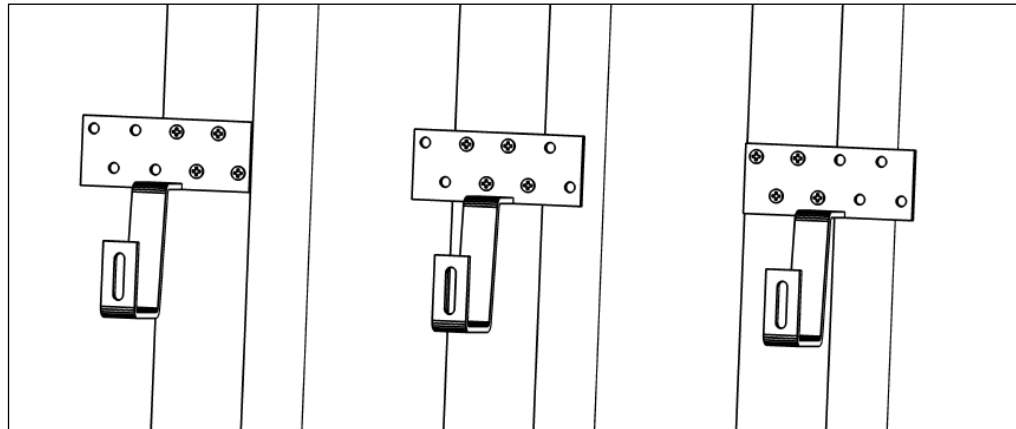

- move back the disassembled tiles to the initial state.

## 5.2 Instalation of the tile holders in case when the roof rafter spacing does not respond to the required spacing of the tile holders

If the spacing of roof rafters does not respond to the required spacing between the tiles, the Monter has to perform a strengthening between the rafters.

It is recommended to strengthen the lath with min 40x60mm bolted to two mounting brackets (min 80x80x60x3 mm) then fasten to the two roof rafters.

The upper edge of the strengthening should be at the same height as the top of the rafters.

Elements needed to strengthening (laths, mounting brackets and screws) are not included in the delivery kit.

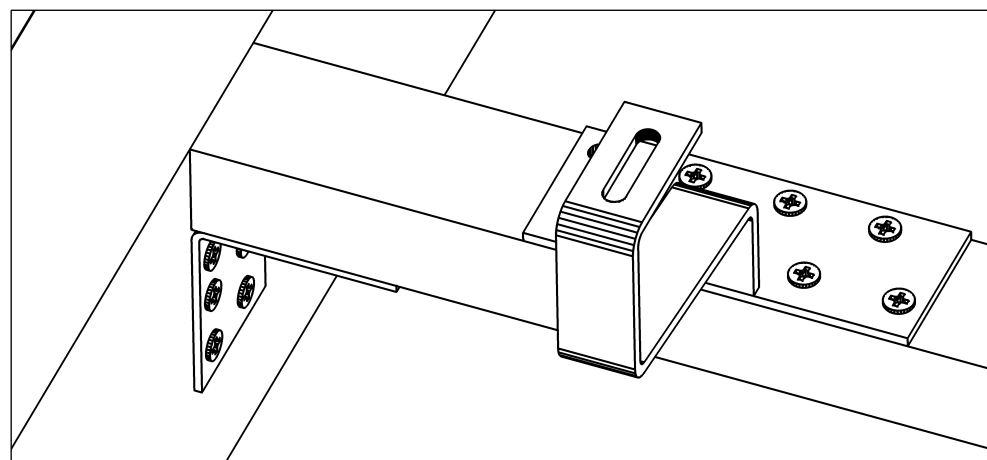

## 5.3 Mounting a collector on the inclined roof

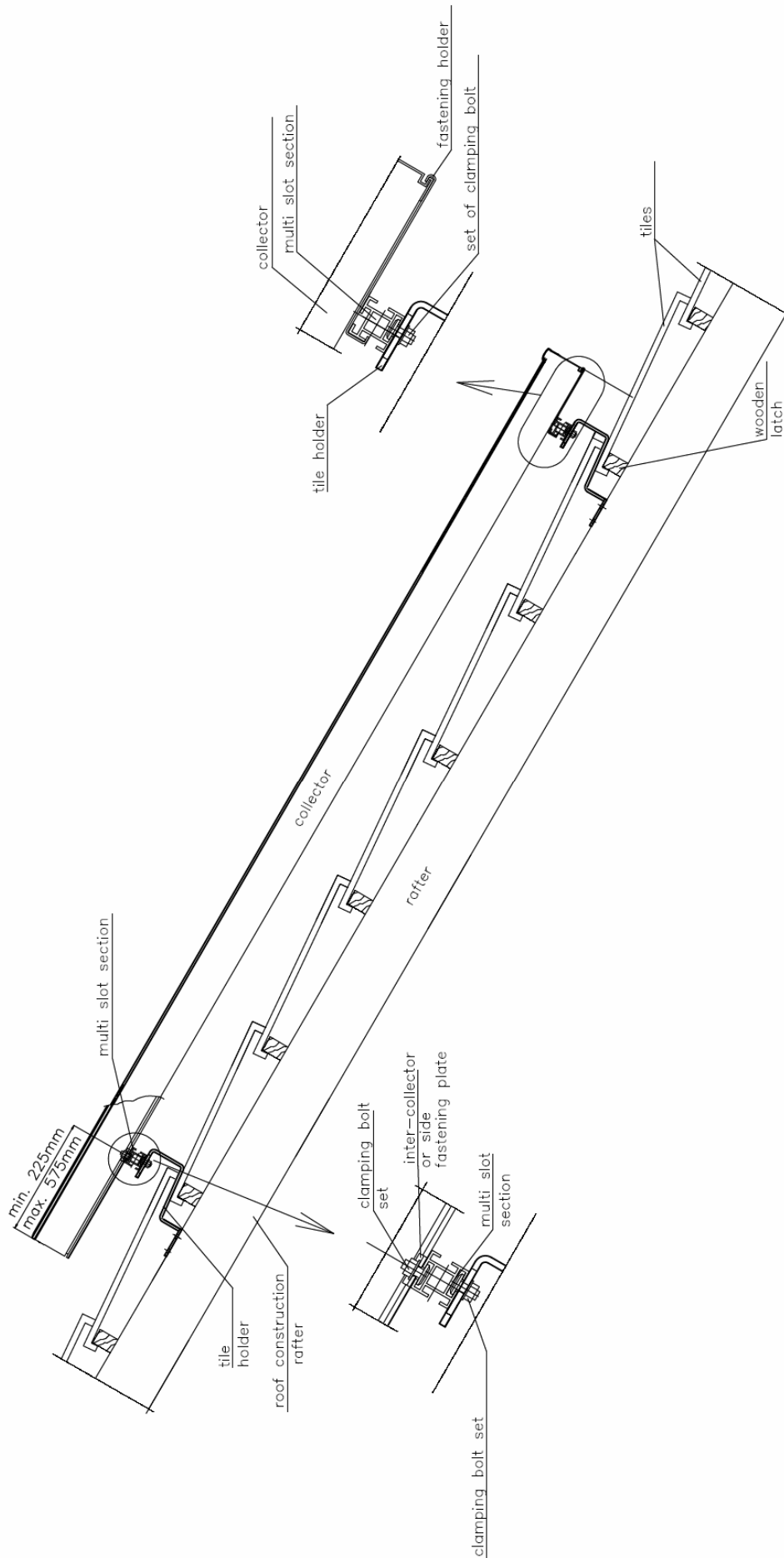

## 5.4. Joining multi-slot sections

The assembly set includes a suitable quantity of the multi-slot sections and connectors depending on a number of collectors.

Table: Configuration of sections and the number of connectors for multi-slot sections.

Number of collectors	ES1V/2.0 ES2V/2.0AL		ES1V/2.65; ES2V/2.65		ES2H/2.65
	Section 1115 mm	Section 2235 mm	Section 1215 mm	Section 2435 mm	Section 2495 mm
1	2 pcs	-	2 pcs	-	2 pcs
2	-	2 pcs	-	2 pcs	4 pcs
3	2 pcs	2 pcs	2 pcs	2 pcs	6 pcs
4	-	4 pcs	-	4 pcs	8 pcs
5	2 pcs	4 pcs	2 pcs	4 pcs	10 pcs

Multi-slot sections need to be connected with each other according to the configuration table, as in the figure below, using the connector (tube fi16x100)

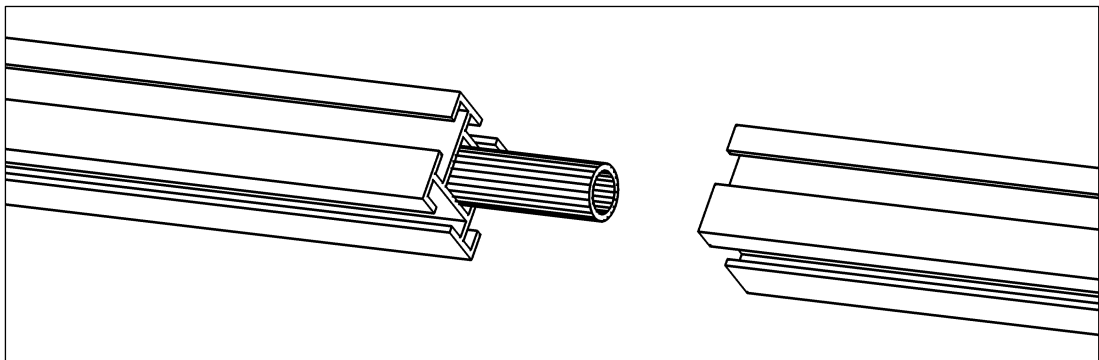

### Directions!

In order to avoid an uncontrollable dislocation of a connector you can use screws as spacers (the screws are not delivered with the set).

The connector itself is not screwed.

- screws should be screwed in the sections at a distant of 105mm from the edge,
- connect the sections with each other using a delivered connecting element.



## 5.5 Connecting multi-slot sections with tile holders.

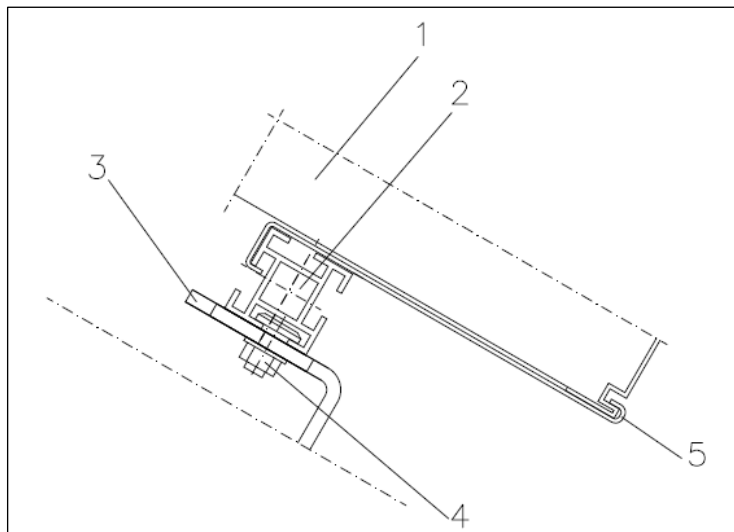

Connecting a multi-slot section with a tile holder.

- 1 – collector,
- 2 – multi-slot section,
- 3 – tile holder,
- 4 – nut and washer,
- 5 – collector fastening holder

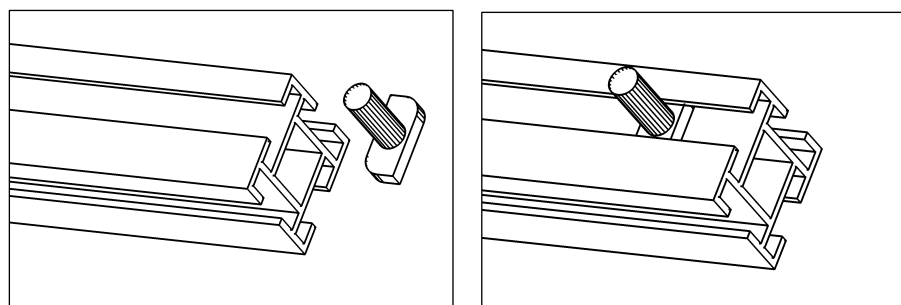

- locate a clamping bolt inside a multi-slot section, see the pictures,

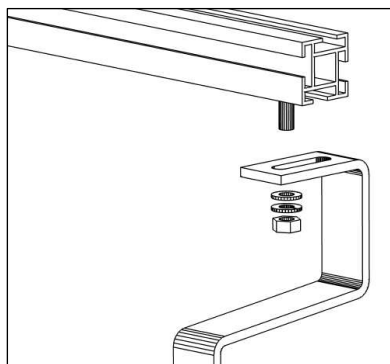

- screw a nut slightly with a tile holder and a washer,
- position the multi-slot sections, according to par. 5.5.

## 5.6 Positioning of multi-slot sections

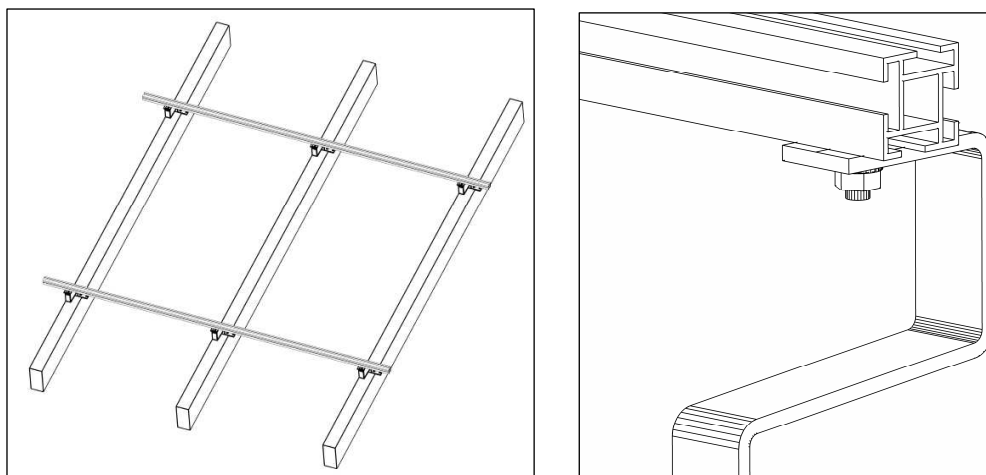

- sections need to be fastened parallel to each other, edges of the upper and the lower section should be in a line,
- after positioning the profiles the bolts must be tightened up.



### Directions!

In order to properly position the profiles it is necessary to use a level and, e.g. a measuring staff.

## 5.7 Assembly of the collector fastening holders.

### 5.7.1 Mounting a collector on a multi-slot-section.

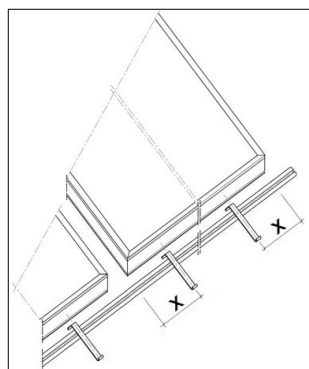

Each collector should rest on two fastening holders, which support and protect it against sliding down.

Fastening holders should be at the distance of  $x = 200 - 250$  mm from the collector edge.

### 5.7.2 Assembly of collector fastening holders.

Collector's fastening holders should be installed in the upper gap of the bottom multi-slot section, see the pictures below.

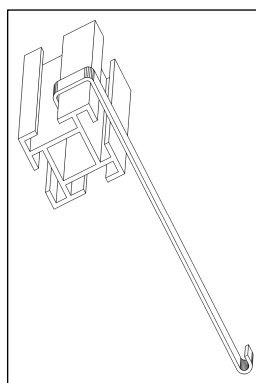
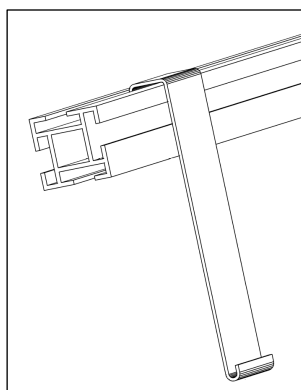

## 5.8. Installation of the collectors

### 5.8.1 Installation of the collectors on the supporting structure.

During the installation of the collectors all safety rules must be obeyed.

#### Hazard



- when the work on the roof is carried out it is necessary to obey safety rules in order to avoid accidents,
- during the work on the roof the installers should be protected against falling down,
- installation should be carried out by at least two persons,
- protective clothing needs to be worn at work,
- upon completing the installation it must be checked if the assembly set and the collectors have been installed in a stable way.



#### Directions!

During transport and installation the collectors need to be protected against falling down.

There are four fasteners for each collector, two on each profile.

- place the bolts in the multi-slot sections, two for each collector,
- locate the collector on the multi-slot sections in such a way that it is supported by the bottom fastening holders,
- collectors should be hydraulically connected by means of a clamping pipe union (see 5.4.1),
- mount the fastening plates at the bottom gap of the collector's frame, screw the nut with the bolt located in the section, as shown below.

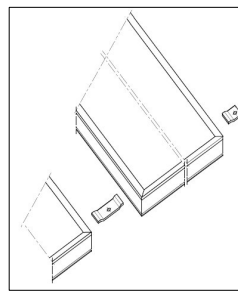

## 6 Hydraulic connection of the collector

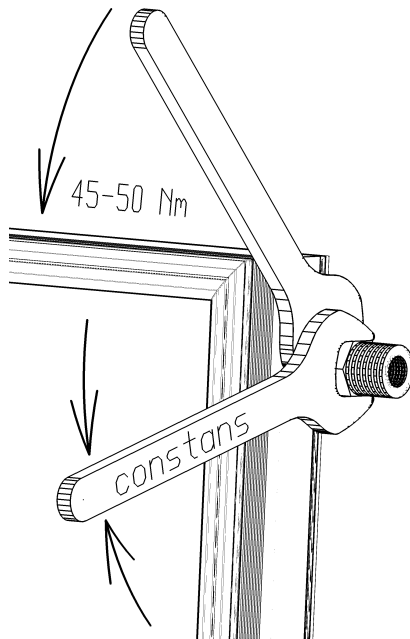

### ATTENTION!

**ALL CLAMPING CONNECTIONS  
SCREW WITH STRENGTH 45 -50 Nm  
COUNTER DURING SCREWING**

Counter wrench with the connector can not change the position during the screwing

### 6.1 Hydraulic connection of the harp collectors ES1V/2.0 and ES1V/2.65



#### Directions!

Hydraulic conduits and fixtures can be connected at the left or right side of the collector battery. The instruction presents the connection at the right side, as an example.

#### One-sided connection of maximum 5 collectors.

When forming a battery you can connect maximum 5 collectors.

### 6.2 Hydraulic connection of the meander collectors ES2V/2.0 AL, ES2V/2,65 and ES2H/2,65



#### Directions!

The power supply and return must be connected to the diagonal of the collector or the battery. The power supply should be connected to the lower connection and the return to the top connector. The Connection for power supply/return is arbitrary – in can be from the left or right sight. In the two other connections should be clamps. The instruction presents the connection at the right side, as an example.

#### One-sided connection of maximum 10 collectors.

When forming a battery you can connect maximum 10 collectors.

#### 6.3.1 Connecting the collectors with a clamping pipe union.

Collectors ES1V/2.0 and ES1V/2.65 – connecting upper connectors pipe

Collectors ES2V/2.0 AL, ES2V/2.65 and ES2H/2.65 – connecting upper and

- bottom connector pipe
- 1 – connector pipe of the collector
  - 2 – strengthening sleeve
  - 3 – pipe union nut
  - 4 – clamping ring
  - 5 – pipe union nipple

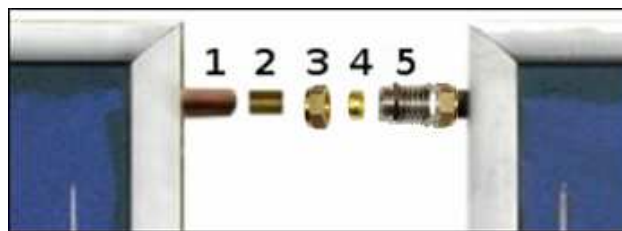

Mount the pipe union on the first collector, then move the second collector closer and fasten the pipe union on both collectors.

- place the strengthening sleeve (2) in the connector pipe of the collector (1),
- pipe union nut (3) should be put on the connector pipe of the collector (1),
- clamping ring (4) should be placed on the connector pipe of the collector,
- screw the nut (3) onto the pipe union body,
- place the strengthening sleeve in the connector pipe of the second collector,
- put the nut on the connector pipe of the second collector,
- place the clamping ring on the connector pipe of the second collector,
- move the second collector closer to the pipe union,
- screw the nut onto the pipe union nipple.

### Directions

The nut should be tightened up so as to secure the leak-tightness of the connection, however, not too strong in order to avoid damage to the connector pipe of the collector.



### 6.3.2 Connection of the collectors feeding

- 1 – connector pipe of the collector
- 2 – strengthening sleeve
- 3 – nut
- 4 – clamping ring
- 5 – elbow body
- 6 – insulated flexible conduit



- place the strengthening sleeve (2) in the connector pipe of the collector (1),
- elbow nut (3) should be put on the connector pipe of the collector (1),
- clamping ring (4) should be placed on the connector pipe of the collector (1),
- screw the nut (3) onto the elbow (5),
- flexible cord nut (6) needs to be screwed on the elbow (5),
- connect the flexible conduit to the solar system.

### 6.3.3 Connection of the collector return

- 1 – connector pipe of the collector,
- 2 – strengthening sleeve,
- 3 – clamp nut,
- 4 – clamping ring,
- 5 – complete pipe-cross with a immersion sleeve,
- 6 – insulated flexible conduit

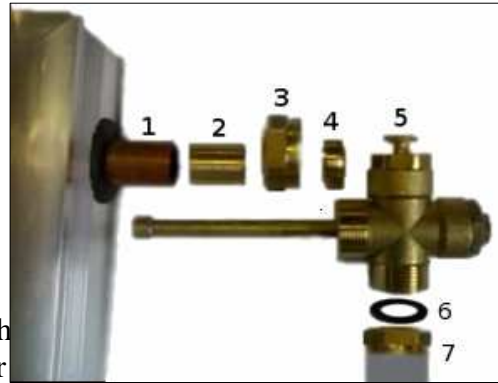

- place the strengthening sleeve (2) in the connector pipe of the collector (1),
- put the clamp nut (3) on the connector pipe of the collector (1),
- place the clamping ring (4) on the connector pipe of the collector (1),
- immersion sleeve with the complete pipe-cross (5) needs to be placed in the connector pipe of the collector (1),
- screw the clamp nut (3) onto the pipe-cross (5) at the left side,
- screw the insulated flexible conduit (6) at the bottom of the pipe-cross (5),
- connect the flexible conduit to the solar system.

### 6.3.4 - Option for mounting an automatic air escape.

If there is not any space for an automatic air escape a manual air escape should be installed.

- 7 – adapter 3/4 " x 3/8 "
- 8 – ball valve 3/8 "
- 9 – automatic air escape 3/8 "



- unscrew the manual air escape from the top of the pipe-cross (5),
- successively screw the adapter (7), valve (8) and automatic air escape (9) at the top of the pipe-cross.



#### Directions!

Due to high temperatures in the solar systems it is necessary to use air escapes made completely of metal.

### 6.3.5 Connection of the clamps

- for collectors ES2V/2.0 AL, ES2V/2,65 and ES2H/2,65

Mount the clamps on the empty connectors (on the diagonal of the collector or the battery).

- 1. Clamp
- 2. Solar collector

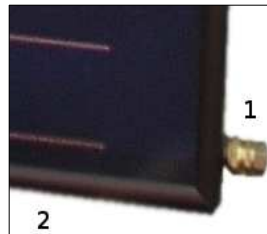

## 6.4 Connection of the temperature sensor

### Damage to the system

In case of wrong installation of a temperature sensor or damage to the signal cable there is a risk of damage to the system.

- signal cable must be protected against damage (e.g. damage caused by birds, rodents) using a protective coat.



Temperature sensor should be installed in an immersion sleeve.

- insert the temperature sensor into the immersion sleeve,
- protect with a clamping spring against moving out.



## 6.5 Connection of collecting conduits

Hydraulic connection with collecting pipes should be executed by means of an insulated flexible conduit. **It is not allowed to connect stiff collective pipes directly to the collector.**

The connection of flexible conduits with the system must be done below the level of the air escape.



### Directions!

Universal roof ventilators and antenna penetration should be used to execute the passage of conduits across the roof.



### Directions!

A cable for the temperature sensor should be laid together with the flexible return conduit.

## 7. Finishing work

### 7.1 Inspection of the installation

Upon completion of the installation work it is necessary to:

- inspect the installation correctness of all elements of the system,
- check the system by means of a pressure test,
- flush the system with water,
- fill in the system with the solar agent.

After the pressure test and water flushing of the system it must be immediately filled up with the solar agent. Otherwise, the tightness test and flushing need to be carried out directly before filling up the installation with the solar agent.

### 7.2 Filling up the installation

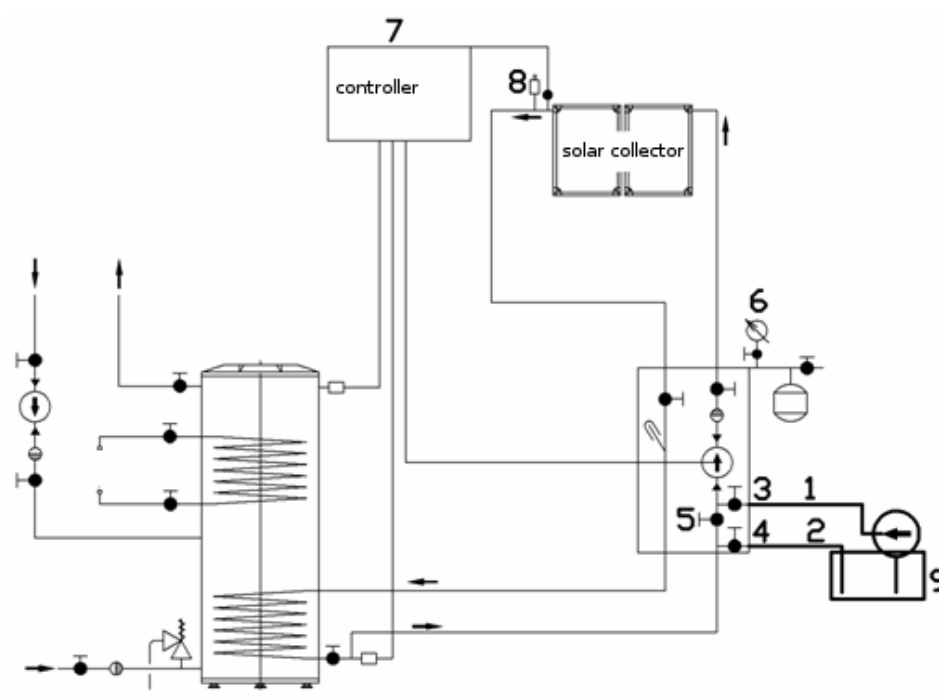

#### Filling up the installation by using a filling station

1. Filling station (9): Connect the hose (1) with the upper valve (3), hose (2) with the bottom valve (4).
2. Fill up the tank of the filling station with the liquid, open the valve (3 and 4) and run the pump.
3. Closing the valve (5) will cause the flow through the solar collectors. During filling and venting the system, you should several times open and close the vent (5).
4. Do not turn off the pump until the installation will be *completely* vent - until from the hose stop flowing air bubbles.
5. Open the vent (5) and close the vent (4) and still pump the fluid until the installation will reach the required pressure,  $p = 2,5$  bar - Pressure measurement (6).
6. Turn on the controller plug (7) to the network and enable  $\sim 230V$  circulation pump in manual mode.
7. Remnants of the air should be removed automatically by unscrewing the valve manually
8. In case of decrease or absence of flow unscrew the central screw in the

circulating pump and let the air exhale. Do this exercise until full vent installation.

9. In the case of pressure drop on the Pressure measurement (6) below 1,5 bar complete up to the to the required pressure  $p=2,5$  bar
10. Disconnect the hose from the filling station from the valves (3, 4)

### 7.3 Venting of the solar installation

After venting the solar installation by means of a filling station and a manual air escape you should close the air escape valve, in case of an automatic air escape it is necessary to close the ball valve.

### 7.4 Insulation work

Insulation work should be done after performing all inspection operations.

#### Directions!

- High temperature and weather resistant insulation must be used to insulate the conduits which are outside the building.  
If necessary, protect the insulation against damage caused by birds.
- High temperature resistant insulation must be used to insulate the conduits inside the building.



## 8. Maintenance and Service

- During the maintenance and other kind of work a collector must be placed firmly to exclude the danger of tripping over and falling down,
- It is not allowed to perform any repair and maintenance work under a lifted collector which has not been protected against casual falling down,
- Repair and maintenance work should be done by means of suitable tools and the servicing personnel should wear protective gloves and shoes,
- Before the commencement of maintenance work it is necessary to wait till the temperature of a collector lowers to such an extent that a risk of getting scalded by hot elements is excluded,
- Overhaul of the solar system needs to be done in accordance with warranty recommendations for particular elements of the system.

In order to guarantee failure-free operation of the whole system it is recommended to carry out the following maintenance work at least once a year:

- *Frost protection* – check the solar fluid resistance to frost by means of a control device (refractometer). In case of a significant fall in frost resistance of the solar fluid it should be replaced and the system must be deaerated once again.
- *System pressure* – working pressure in the solar system needs to be checked. After the start-up period no drop of pressure is permissible.
- *Expansion vessel* – input pressure of the expansion vessel should be checked. To this end, disconnect the vessel from the system and measure the pressure. The input pressure should be 2,5 bars.

The control and protection system should also be inspected along with the structure for supporting and fixing a collector on the roof.

**In order to guarantee the proper operation of the whole system, every time we recommend you to enter into a contract for maintenance work with a specialist installation firm.**